

УДК 541.144; 544.77

УДК 541.144; 544.77

ИСПОЛЬЗОВАНИЕ КОЛЛОИДНЫХ МЕЛКОДИСПЕРСНЫХ ЧАСТИЦ СЕРЕБРА В ТЕХНОЛОГИЯХ ВОДОПОДГОТОВКИ

***И. Игнатов, **О. В. Мосин**

**Научно-исследовательский центр медицинской биофизики (НИЦМБ), Болгария; **Московский государственный университет прикладной биотехнологии, Российская Федерация*

В статье рассмотрены методы получения мелкодисперсных наночастиц коллоидного серебра и области его практического применения в наноиндустрии, бионанотехнологии, медицине и смежных отраслях промышленности, в т. ч. водоподготовке и водоочистке. Рассмотрены механизмы бактерицидного воздействия коллоидного серебра на микробную клетку с точки зрения адсорбционных, электростатических, ферментативных и мутагенных теорий. Серебро оказывает бактерицидное и бактериостатическое воздействие по отношению более чем 500 видов микроорганизмов. Эффект уничтожения бактерий препаратами серебра в 1500 раз выше действия такой же концентрации фенола и в 3,5 раза выше действия сулемы. Показано, что эффекты коллоидного серебра определяются концентрацией, размерами и стабильностью мелкодисперсных наночастиц в водных растворах, которые получают с помощью различных физико-химических, биохимических и биотехнологических методов.

Ключевые слова: коллоидное серебро, наночастицы, нанобиотехнология, водоподготовка

ВИКОРИСТАННЯ КОЛОЇДНИХ ДРІБНОДИСПЕРСНИХ ЧАСТОК СРІБЛА В ТЕХНОЛОГІЯХ ВОДОПІДГОТОВКИ

***І. Ігнатов, **О.В. Мосін**

**Науково-дослідний центр медичної біофізики (НІЦМБ), Болгарія; **Московський державний університет прикладної біотехнології, Російська Федерація*

У статті розглянуто методи отримання дрібнодисперсних наночастинок колоїдного срібла та області його практичного застосування в наноіндустрії, біонанотехнології, медицині та суміжних галузях промисловості, в т. ч. водопідготовці та водоочищення. Розглянуто механізми бактерицидного впливу колоїдного срібла на микробну клітину з погляду адсорбційних, електростатичних, ферментативних і мутагенних теорій. Срібло має бактерицидну і бактериостатичну вплив по відношенню більш ніж 500 видів мікроорганізмів. Ефект знищення бактерій препаратами срібла в 1500 разів вище дії такої ж концентрації фенолу і в 3,5 рази вище дії сулемі. Показано, що ефекти колоїдного срібла визначаються концентрацією, розмірами і стабільністю дрібнодисперсних наночастинок у водних розчинах, які отримують за допомогою різних фізико-хімічних, біохімічних і біотехнологічних методів.

Ключові слова: колоїдне срібло, наночастинки, нанобіотехнологія, водопідготовка.

Впервые поступила в редакцию 06.10.2015 г. Рекомендована к печати на заседании редакционной коллегии после рецензирования.

UDC 543.42.062: 577.3

ISOTOPE PURIFICATION OF DRINKING WATER FROM HEAVY ISOTOPES – DEUTERIUM (²H), TRITIUM (³H) AND OXYGEN (¹⁸O)

***O. Mosin, **I. Ignatov**

**Moscow State University of Applied Biotechnology, Russian Federation;
**The Scientific Research Center of Medical Biophysics (SRCMB), Bulgaria*

Introduction

An important indicator of the quality of drinking water is the isotopic composition. Natural water consists on 99.7 mol.% from water having chemical formula H₂¹⁶O, the molecules of which are formed by natural atoms of hydrogen ¹H and oxygen ¹⁶O. The remaining 0.3 mol.% of water are represented by isotopologues – the isotope varieties of water molecules. As isotopologues in natural water present heavy oxygen (H₂¹⁷O and H₂¹⁸O), heavy water (H₂¹⁶O) and tritium (super-heavy) water (T₂¹⁶O), the last is radioactive.

The amount of natural isotopologues of water, in which the atoms ¹H, D, T, ¹⁶O, ¹⁷O and ¹⁸O are presented in various

combinations compiles 18, in which 9 combinations (H₂¹⁶O, H₂¹⁷O, H₂¹⁸O, HD¹⁶O, HD¹⁷O, HD¹⁸O, D₂¹⁶O, D₂¹⁷O, D₂¹⁸O) are non-radioactive formed with deuterium and 9 combinations are radioactive (T₂¹⁶O, T₂¹⁷O, T₂¹⁸O, DT¹⁶O, DT¹⁷O, DT¹⁸O, HT¹⁶O, HT¹⁷O, HT¹⁸O) isotopologues of water formed with tritium [1]. These data indicate that there is a possibility of existence in nature the water molecules that contain any of the three isotopes of hydrogen (H, D, T) and three oxygen isotopes (¹⁶O, ¹⁷O and ¹⁸O) in any combination. 99.97 mol.% of all water in the hydrosphere is represented by protium (H₂¹⁶O) water, the proportion of heavy (D₂¹⁶O) water is less than 0.02 mol.%. On the average, natural waters contain on

10.000 molecules 9973 molecules of $H_2^{16}O$, 3 molecules of $HD^{16}O$, 4 molecules of $H_2^{17}O$, 20 molecules of $H_2^{18}O$ and 2 molecules of $D_2^{16}O$ [2]. Even rarer than $D_2^{16}O$, occur 9 natural isotopologues of radioactive water containing tritium (T) – a radioactive element with a half-life of 12.26 years. Tritium is formed in the upper atmosphere, where occur natural nuclear reactions of bombardment of nitrogen and oxygen atoms with neutrons of cosmic radiation. The small amount of tritium (super-heavy water) falls to the Earth as part of sediments. Every minute per 1 cm^2 of the Earth's surface fall ~8–9 of tritium atoms. In nature $T_2^{16}O$ is distributed unevenly: in the continental waters the content of $T_2^{16}O$ is more than in the oceans; polar ocean waters have more content of $T_2^{16}O$ than the equatorial waters [3]. Throughout the Earth's hydrosphere there are about 15 kg of $T_2^{16}O$.

The "heavy" varieties of water on its physical-chemical properties and the adverse effects on biological objects are substantially different from ordinary water. Thus, $D_2^{16}O$ boils at +101.44 °C, freezes at +3.82 °C, has density at +20 °C (1.105 g/cm^3), with the maximum density occurs not at +4 °C as $H_2^{16}O$ but at +11.2 °C (1.106 g/cm^3) [4]. $T_2^{16}O$ boils at +104 °C, freezes at +4.9 °C, has density 1.33 g/cm^3 . The physical and chemical properties of $H_2^{17}O$ and $H_2^{18}O$ are less different from those of $H_2^{16}O$ than $D_2^{16}O$. These water isotopologues are produced by chemical and isotopic exchange and cryogenic rectification of hydrogen isotopes, and used as tracers with labeled oxygen in various chemical studies [5].

Taking into consideration the above mentioned factors it is recommended for water treatment plants to carry out the isotope fractionation of water in order to purify water from heavy isotopes of D, T and ^{18}O . Now the scientific research to improve the isotope quality of drinking water is carried out in all countries, including Russia and Bulgaria. However, the existing water treatment plants and water treatment technologies often could not cope with the tasks of harvesting water from heavy isotopes. Therefore, in recent years have been developed new modern advanced methods and technologies for isotope fractionation and purification of drinking water from heavy isotopes of D, T and ^{18}O , that can be found the further large-scale practical application.

The purpose of this paper is to examine the fundamental possibility of large scale production of deuterium depleted water facilitated by the use of different technologies and apparatus, as well as the study of the biological effects of water with the reduced deuterium content on the human body.

Experimental Part

Material and Methods

Chemicals

For preparation of growth media was used $D_2^{16}O$ (99.9 atom.%), DCl (95.5 atom.%) and $H_2^{18}O$ (99.5 atom.% ^{18}O), purchased from the "Isotope" Russian Research Centre (St. Petersburg, Russian Federation). Inorganic salts ("Reanal", Hungary) were preliminary crystallized in $D_2^{16}O$ and dried in vacuum before the using. $D_2^{16}O$ was distilled over $KMnO_4$ with the subsequent control of the isotope enrichment by 1H -NMR-spectroscopy on a Bruker WM-250 device ("Bruker",

Germany) (working frequency: 70 MHz, internal standard: Me_4Si). According to 1H -NMR, the level of isotopic purity of growth media usually was by ~8–10 atom% lower than the isotope purity of the initial $D_2^{16}O$.

Biological objects

The objects of the study were various microorganisms, realizing methylotrophic, chemoheterotrophic, photoorganotrophic, and photosynthetic ways of assimilation of carbon substrates. The initial strains were obtained from the State Research Institute of Genetics and Selection of Industrial Microorganisms (Moscow, Russia):

1. *Brevibacterium methylicum B-5652*, a leucine auxotroph Gram-positive strain of facultative methylotrophic bacterium, L-phenylalanine producer, assimilating methanol via the NAD^+ dependent methanol dehydrogenase variant of ribulose-5-monophosphate cycle (RuMP) of carbon fixation;

2. *Bacillus subtilis B-3157*, a polyauxotrophic for histidine, tyrosine, adenine, and uracil spore-forming aerobic Gram-positive chemoheterotrophic bacterium, inosine producer, realizing hexose-6-mono-phosphate (GMP) cycle of carbohydrates assimilation;

3. *Halobacterium halobium ET-1001*, photoorganotrophic carotenoid-containing strain of extreme halobacteria, synthesizing the photochrome transmembrane protein bacteriorhodopsin;

4. *Chlorella vulgaris B-8765*, photosynthesizing single-cell green alga.

Adaptation technique

The initial microorganisms were modified by adaptation to deuterium by plating individual colonies onto 2 % (w/v) agarose growth media with stepwise increasing gradient of $D_2^{16}O$ concentration and subsequent selection of individual cell colonies stable to the action of $D_2^{16}O$. As a source of deuterated growth substrates for the growth of chemoheterotrophic bacteria and chemoorganoheterotrophic bacteria was used the deuterated biomass of facultative methylotrophic bacterium *B. methylicum*, obtained via a multi-stage adaptation on solid 2 % (w/v) agarose M9 media with an increasing gradient of $D_2^{16}O$ (from 0; 24.5; 49.0; 73.5 up to 98.0 % (v/v) $D_2^{16}O$). The raw deuterated biomass (output, 100 gram of wet weight per 1 liter of liquid culture) was suspended in 100 ml of 0.5 N DCl (in $D_2^{16}O$) and autoclaved for 30–40 min at 0.8 atm. The suspension was neutralized with 0.2 N KOH (in 2H_2O) to pH = 7.0 and used as a source of growth substrates while adaptation and growing the chemoheterotrophic bacterium *B. subtilis* and the photo-organotrophic halobacterium *H. halobium*.

Scanning electron microscopy (SEM)

The SEM was carried out on JSM 35 CF (JEOL Ltd., Korea) device, equipped with SE detector, thermomolecular pump, and tungsten electron gun (Harpin type W filament, DC heating); working pressure – 10-4 Pa (10-6 Torr); magnification – $\times 150000$, resolution – 3.0 nm, accelerating voltage – 1–30 kV; sample size – 60–130 mm.

Mass spectrometry

For the evaluation of deuterium enrichment levels the EI and the FAB mass spectrometry was used. EI mass spectra

were recorded on MB-80A device ("Hitachi", Japan) with double focusing (the energy of ionizing electrons – 70 eV; the accelerating voltage – 8 kV; the cathode temperature – 180–200 °C) after the amino acid modification into methyl esters of N-5-dimethylamino(naphthalene)-1-sulfonyl (dansyl) amino acid derivatives according to an earlier elaborated protocol. FAB-mass spectra were recorded on a VG-70 SEQ chromatograph ("Fisons VG Analytical", USA) equipped with a cesium Cs⁺ source on a glycerol matrix with accelerating voltage 5 kV and ion current 0,6–0,8 mA. The calculation of deuterium enrichment of the molecules was carried out using the ratio of contributions of molecular ion peaks of deuterated compounds extracted on ²H₂O-media relative to the control obtained on H₂O.

The reversed-phase high performance liquid chromatography (RP-HPLC)

The RP-HPLC was performed on a Beckman Gold System (USA) chromatograph (250×4.6 mm), equipped with Model 126 UV-Detector (USA), 20±25 °C. Stationary phase – Ultrasphere ODS 5 μm; mobile phase – the linear gradient of 5 mM KH₂PO₄–acetonitrile; elution rate – 0,5 ml/min, detection at λ = 210 nm.

IR-spectroscopy

IR-spectra of water samples were registered on Brucker Vertex ("Brucker", Germany) Fourier-IR spectrometer (spectral range: average IR – 370–7800 cm⁻¹; visible – 2500–8000 cm⁻¹; permission – 0.5 cm⁻¹; accuracy of wave number – 0.1 cm⁻¹ on 2000 cm⁻¹) and on Thermo Nicolet Avatar 360 Fourier-transform IR.

Results and discussion

The study of kinetic isotope effects of D₂¹⁶O and H₂¹⁸O

The research was conducted on cells of various prokaryotic and eukaryotic organisms, including methylotrophic, chemoheterotrophic, photoorgano-heterotrophic bacteria and green algae. For the preparation of growth media was used D₂¹⁶O (99.9 atom.% D) and H₂¹⁸O (99.5 atom.% ¹⁸O) and solutions of D₂¹⁶O and H₂¹⁶O of isotopic composition of various concentrations, containing stepwise increasing concentrations of deuterium.

According to our research, the biological objects are very sensitive to changes in the isotopic composition of the water. When being exposed to water of different isotopic composition the reaction varies depending on the isotopic composition of water. The isotopologues of water differ from each other in physical properties (Table 1). The chemical structure of molecules of water isotopologues is similar to the chemical structure of H₂¹⁶O, with a very small difference in the value of the length of covalent bonds and the angles between them. However, the difference in atomic mass of isotopes in natural water is high, therefore they are able to be strongly fractionated in natural processes: D/H → 100%, ¹⁸O/¹⁶O → 12.5%. Most effectively, the isotopes of hydrogen and oxygen are fractionated during evaporation–condensation and crystallization of water.

Table 1

Changes in the physical properties of water with the isotopic substitution

Physical properties	H ₂ ¹⁶ O	D ₂ ¹⁶ O	H ₂ ¹⁸ O
Density at 20 °C, g/cm ³	0.997	1.105	1.111
Temperature of maximum density, °C	3,98	11,24	4,30
Melting point under 1 atm, °C	0	3.81	0.28
Boiling point temperature at 1 atm, °C	100,00	101,42	100,14
The vapor pressure at 100 °C, mm Hg	760,00	721,60	758,10
Viscosity at 20 °C, cP	1,002	1,47	1,056

The isotopologues of water have considerably different equilibrium vapor pressures. At the same time, the smaller the mass of a molecule of water, the higher is the vapor pressure, so the vapor in equilibrium with the water, is enriched with light isotopes of hydrogen ¹H and oxygen ¹⁶O, which allows carry out the isotope fractionation of water. The isotopic fractionation is carried out by following methods – isotopic exchange in the presence of Pd and Pt, the electrolysis of water in combination with a catalytic isotopic exchange between H₂¹⁶O and H₂, column rectification of cooled gaseous H₂, vacuum freezing of cold vapor followed by the thawing etc. [6].

The main parameter of kinetic isotopic exchange is a partition coefficient K_p characterizing the distribution of isotopes between substances in a state of equilibrium determined by the ratio of mass concentrations of isotopes in the reactants. With a uniform equilibrium distribution of isotopes the distribution ratio is equal to 1. However, in practice, a uniform distribution of isotopes in the molecules of the reactants takes place only for the isotopes of light elements. So, for the light isotope ¹⁶O with a slight difference of the atomic mass at chemical equilibrium of isotope exchange each isotope is distributed uniformly among the molecules of the reactants. Unlike light isotopes, for the isotopes of heavy elements as deuterium (D) and tritium (T) uneven in distribution among molecules of certain substances may reach hundreds of percent.

The deviation from the uniform distribution depends not only on the weight of the isotopes, but also on the chemical composition of substances between which the isotopic exchange takes place. Furthermore, the distribution ratio for various isotopes depends on the temperature and at its increasing tends to be close to 1.

In the line of stable isotopes ¹⁷O, ¹⁸O and D the most large kinetic isotope effects stipulated by the difference in the rate constants of chemical reactions with the ratio k_H/k_D

= 7–10 are observed in heavy water for C–H/C–D, N–H/N–D and $^{16}\text{O–H}/^{16}\text{O–D}$ bonds [7]. Therefore, kinetic isotope effects due to the mass difference, preferably, are determined by deuterium. In mixtures of D_2^{16}O with H_2^{16}O the isotopic exchange occurs with high speed with the formation of semi-heavy water (H^2DO): $\text{D}_2^{16}\text{O} + \text{H}_2^{16}\text{O} = \text{HD}^{16}\text{O}$. For this reason deuterium presents in smaller content in aqueous solutions in form of HD^{16}O , while in the higher content – in form of D_2^{16}O . The chemical reactions in D_2^{16}O are somehow slower compared to H_2^{16}O . D_2^{16}O is less ionized, the dissociation constant of D_2^{16}O is smaller, and the solubility of the organic and inorganic substances in D_2^{16}O is smaller compared to these ones in H_2^{16}O [8]. Due to isotopic effects the hydrogen bonds with the participation of deuterium are slightly stronger than those ones formed of hydrogen. The above factors as well as a large density and viscosity of D_2^{16}O compared with H_2^{16}O result in a change the rates (slowing down) and the specificity of enzymatic reactions in D_2^{16}O [9]. However, there are reactions which rates are higher in D_2^{16}O than H_2^{16}O . In general these reactions are catalyzed by D^+ ions or H^+ or $^{16}\text{OD}^-$ and $^{16}\text{OH}^-$.

The numerous studies with various biological objects in D_2^{16}O proved that when biological objects are exposed to water with different deuterium content, their reaction varies depending on the isotopic composition of water (the content of deuterium in water) and the magnitude of isotope effects determined by the difference of constants of chemical reactions rates $k_{\text{H}}/k_{\text{D}}$ in H_2^{16}O and D_2^{16}O [10]. The maximum kinetic isotopic effect observed at ordinary temperatures in chemical reactions leading to rupture of bonds involving hydrogen and deuterium atoms lies in the range $k_{\text{H}}/k_{\text{D}} = 5–8$ for C–H versus C–D, N–H versus N–D, and $^{16}\text{O–H}$ versus $^{16}\text{O–D}$ -bonds [11].

At placing a cell onto D_2^{16}O -media lacking protons, not only D_2^{16}O is removed from a cell due to isotopic (H–D) exchange, but also there are occurred a rapid isotopic (H–D) exchange in hydroxyl (^{16}OH), sulfhydryl ($-\text{SH}$) and amino ($-\text{NH}_2$) groups in all molecules of organic substances, including proteins, nucleic acids, carbohydrates and lipids. It is known, that in these conditions only covalent C–H bond is not exposed to isotopic (H–D) exchange and, thereof only molecules with bonds such as C–D can be synthesized de novo. Depending on the position of the deuterium atom in the molecule, there are distinguished primary and secondary isotopic effects mediated by intermolecular interactions. In this aspect, the most important for the structure of macromolecules are dynamic short-lived hydrogen (deuterium) bonds formed between the electron deficient H(D) atoms and adjacent electronegative O, C, N, S- heteroatoms in the molecules, acting as acceptors of H-bond. The hydrogen bond, based on weak electrostatic forces, donor-acceptor interactions with charge-transfer and intermolecular van der Waals forces, is of the vital importance in the chemistry of intermolecular interactions and maintaining the spatial structure of macromolecules in aqueous solutions. Another important property is defined by the three-dimensional structure of D_2^{16}O molecule having the tendency to pull together hydrophobic groups of macromolecules to minimize their disruptive effect

on the hydrogen (deuterium)-bonded network in D_2^{16}O . This leads to stabilization of the structure of protein and nucleic acid macromolecules in the presence of D_2^{16}O . That is why, the structure of macromolecules of proteins and nucleic acids in the presence of D_2^{16}O is somehow stabilized [12].

Evidently the cell implements the special adaptive mechanisms promoting the functional reorganization of vital systems in D_2^{16}O . Thus, for the normal synthesis and function in D_2^{16}O of such vital compounds as nucleic acids and proteins contributes to the maintenance of their structure by forming hydrogen (deuterium) bonds in the molecules. The bonds formed by deuterium atoms are differed in strength and energy from similar bonds formed by hydrogen. Somewhat greater strength of D– ^{16}O bond compared to H– ^{16}O bond causes the differences in the kinetics of reactions in H_2^{16}O and D_2^{16}O . Thus, according to the theory of a chemical bond the breaking up of covalent H–C bonds can occur faster than C–D bonds, the mobility of $\text{D}_3^{16}\text{O}^+$ ion is lower on 28,5% than H_3O^+ ion, and $^{16}\text{OD}^-$ ion is lower on 39,8% than $^{16}\text{OH}^-$ ion, the constant of ionization of D_2^{16}O is less than that of H_2^{16}O . These chemical-physical factors lead to the slowing down in the rates of enzymatic reactions in D_2^{16}O [13]. However, there are also such reactions which rates in D_2^{16}O are higher than in H_2^{16}O . In general these reactions are catalyzed by $\text{D}_3^{16}\text{O}^+$ or $\text{H}_3^{16}\text{O}^+$ ions or $^{16}\text{OD}^-$ and $^{16}\text{OH}^-$ ions. The substitution of H with D affects the stability and geometry of hydrogen bonds in an apparently rather complex way and may through the changes in the hydrogen bond zero-point vibration energies, alter the conformational dynamics of hydrogen (deuterium)-bonded structures of DNA and proteins in D_2^{16}O . It may cause disturbances in the DNA-synthesis during mitosis, leading to permanent changes on the DNA structure and consequently on cell genotype [14]. The isotopic effects of deuterium, which would occur in macromolecules of even a small difference between hydrogen and deuterium, would certainly have the effect upon the structure. The sensitivity of enzyme function to the structure and the sensitivity of nucleic acid function (genetic and mitotic) would lead to a noticeable effect on the metabolic pathways and reproductive behavior of an organism in the presence of D_2^{16}O . And next, the changes in dissociation constants of the DNA and protein ionizable groups when transferring the macromolecule from H_2^{16}O into D_2^{16}O may perturb the charge state of the DNA and protein molecules. All this can cause variations in nucleic acid synthesis, which can lead to structural changes and functional differences in the cell and its organelles. Hence, the structural and dynamic properties of the cell membrane, which depends on qualitative and quantitative composition of membrane's fatty acids, can also be modified in the presence of D_2^{16}O . The cellular membrane is one of the most important organelles in the bacteria for metabolic regulation, combining apparatus of biosynthesis of polysaccharides, transformation of energy, supplying cells with nutrients and involvement in the biosynthesis of proteins, nucleic acids and fatty acids. Obviously, the cell membrane plays an important role in the adaptation to D_2^{16}O . But it has been not clearly known what occurs with the membranes – how they react to the

replacement of protium to deuterium and how it concerns the survival of cells in D₂¹⁶O-media devoid of protons.

The comparative analysis of the fatty acid composition of deuterated cells of chemoheterotrophic bacteria *B. subtilis*, obtained on the maximum deuterated medium with 99,9 atom.% D₂¹⁶O, carried out by the HPLC method, revealed significant quantitative differences in the fatty acid composition compared to the control obtained in ordinary water (Figure 1a). Characteristically, in a deuterated sample fatty acids with retention times at 33.38; 33.74; 33.26 and 36.03 min are not detected in the HPLC-chromatogram (Fig. 1b). This result is apparently due to the fact that the cell membrane is one of the first cell organelles, sensitive to the effects of D₂¹⁶O, and thus compensates the changes in rheological properties of a membrane (viscosity, fluidity, structure) not only by quantitative but also by the qualitative composition of the membrane fatty acids. The similar situation was observed with the separation of other natural compounds (proteins, amino acids, carbohydrates) extracted from the deuterio-biomass of the microorganisms obtained from the maximally deuterated D₂¹⁶O-medium.

The isotope effects of D₂¹⁶O are determined by the concentration of deuterium in natural water. The average ratio of atoms of deuterium and hydrogen in natural waters compiles ~1:5700. In natural waters, the deuterium content is distributed irregularly: from 0.02–0.03 mol.% for river and sea water, to 0.015 mol.% for water of Antarctic ice – the most purified from deuterium natural water containing deuterium in 1.5 times less than that of seawater.

The concentration of water molecules containing heavy isotopes of D, ¹⁷O and ¹⁸O, in natural water varies within the limits laid down in the basic standards of the isotopic composition of the hydrosphere – SNOW and SLAP (Table 2).

Table 2

The calculated mass concentrations of isotopologues in natural water corresponding to international standards of SMOW* and SLAP**

Isotopologue	Molecular mass, u	Isotopic content, g/kg	
		SMOW	SLAP
¹ H ₂ ¹⁶ O	18,01056470	997,032536356	997,317982662
¹ HD ¹⁶ O	19,01684144	0,328000097	0,187668379
D ₂ ¹⁶ O	20,02311819	0,000026900	0,000008804
¹ H ₂ ¹⁷ O	19,01478127	0,411509070	0,388988825
¹ HD ¹⁷ O	20,02105801	0,000134998	0,000072993
D ₂ ¹⁷ O	21,02733476	0,000000011	0,000000003
¹ H ₂ ¹⁸ O	20,01481037	2,227063738	2,104884332
¹ HD ¹⁸ O	21,02108711	0,000728769	0,000393984
D ₂ ¹⁸ O	22,02736386	0,000000059	0,000000018

Notes:

*SMOW (average molecular weight = 18.01528873 u)

**SLAP (average molecular weight = 18.01491202 u)

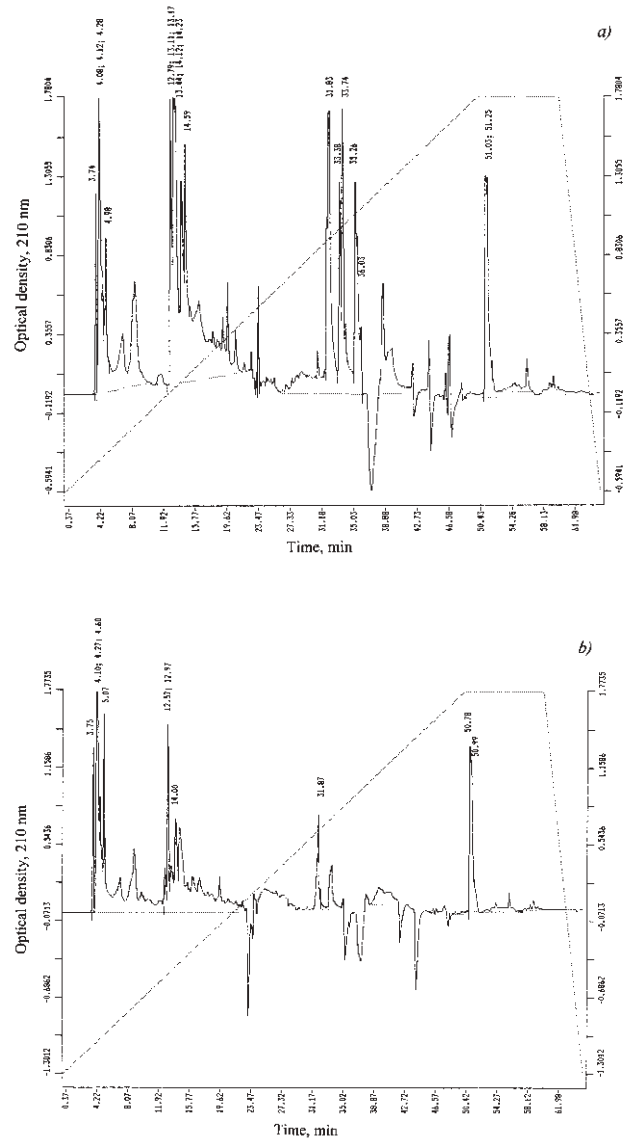

Fig. 1. – HPLC-chromatograms of fatty acids obtained from protonated (a) and deuterated (b) cells of *B. subtilis* on the maximally deuterated D₂¹⁶O-medium: Beckman Gold System (Beckman, USA) chromatograph (4.6×250 mm); stationary phase: Ultrasphere ODS, 5 μm; mobile phase: linear gradient 5 mM KH₂PO₄–acetonitrile (shown in phantom), elution rate: 0.5 ml/min, detection at λ = 210 nm. The peaks with retention time 3.75 min (instead of 3.74 minutes in the control); 4.10; 4.27; 4.60 (instead of 4.08; 4.12; 4.28 in the control), 5.07 (instead of 4.98 in control); 12.57; 12.97 (instead of 12.79; 13.11; 13.17 in control); 14.00 (instead of 14.59 in the control); 31.87 (instead of 31.83 in the control); 33.38; 33.74; 33.26; 36.03; 50.78; 50.99 (instead of 51.03; 51.25 for control) correspond to individual intracellular fatty acids

According to the international SMOW standard (Oceanic water), corresponding to deep waters of the oceans, which is very stable isotopic composition, the absolute content of D and ¹⁸O (isotopic shift, δ, ppm) in sea water: D/H = (155.76±0.05)·10⁻⁶ (155.76 ppm) and (155,76±0,05)·10⁻⁶ (155,76 ppm) [15]. For the SLAP standard (the Atlantic

oceanic water) the isotopic shifts for D and ^{18}O in seawater: $\text{D}/\text{H} = 89 \cdot 10^{-6}$ (89 ppm) and $^{18}\text{O}/^{16}\text{O} = 1894 \cdot 10^{-6}$ (1894 ppm) [16]. The content of the lightest isotopologue – H_2^{16}O in water corresponding to the SMOW standard is 997,0325 g/kg (99,73 mol.%), and for the SLAP standard – 997,3179 g/kg (99,76 mol.%) (Table 2). In surface waters, the ratio $\text{D}/\text{H} = (1,32\text{--}1,51) \cdot 10^{-4}$, while in the coastal seawater – $(1,55\text{--}1,56) \cdot 10^{-4}$.

The natural waters of CIS countries are characterized by negative deviations from the SMOW standard to $(1,0\text{--}1,5) \cdot 10^{-5}$, in some places up to $(6,0\text{--}6,7) \cdot 10^{-5}$, but there are also observed positive deviations at $2,0 \cdot 10^{-5}$. Water of other underground and surface water sources contains varied amounts of deuterium (isotopic shifts) – from $\delta = +5,0$ D,%, SMOW (the Mediterranean Sea) up to $\delta = -105$ D,%, SMOW (the Volga River).

The analyses of water from various sources of Russia and Bulgaria show that the mountain water contains on average $\sim 2\text{--}5\%$ less deuterium in form of HD^{16}O , than river water and sea water. In natural waters, the deuterium content is distributed irregularly: from 0,02–0,03 mol.% for river and sea water, to 0,015 mol.% for water of Antarctic ice – the most purified from deuterium natural water containing deuterium in 1,5 times less than that of seawater [17]. The thawed snow and glacial water in the mountains and some other regions of the Earth also contain less deuterium than ordinary drinking water. On average, 1 ton of river water contains 150–200 g deuterium. The average ratio of H/D in nature makes up approximately 1:5700. According to the calculations, the human body throughout life receives about 80 tons of water containing in its composition 10–12 kg of deuterium and associated amount of heavy isotope ^{18}O . Such a considerable amount of heavy isotopes in the composition of drinking water is capable to cause the genetic damage, lead to the development of cancer, and to initiate aging. According to our study, a high concentration of heavy water is toxic to the body; chemical reactions in the environment, it is slow in comparison with ordinary water, the hydrogen bonds involving deuterium conventional somewhat stronger hydrogen bonds due to the kinetic isotope effect deuterium [18]. According to our studies the animal cells can withstand up to 25–30 % D_2^{16}O , plants – up to 60% D_2^{16}O , while protozoa and the cells are able to exist on 90 % D_2^{16}O (Fig. 2).

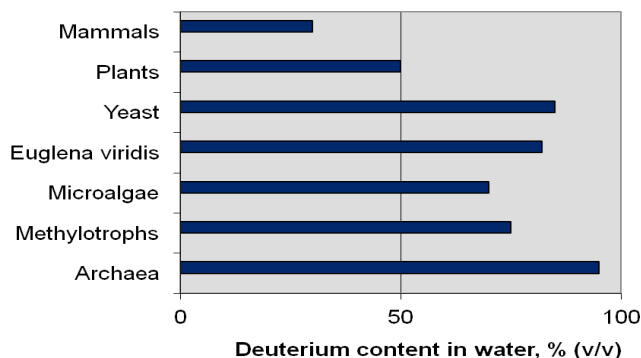

Fig. 2. – Cell survival of various prokaryotic and eukaryotic organisms in water with different deuterium content (% v/v)

Once in the body, D_2^{16}O can cause metabolic disorders, kidney and hormonal regulation. At high concentrations in the body D_2^{16}O inhibited the enzymatic reactions, cell growth, carbohydrate metabolism and synthesis of nucleic acids. The effects of D_2^{16}O are particularly susceptible to the systems that are most sensitive to the substitution of H^+ with D^+ , which use high speed formation and rupture of the hydrogen bonds. Such cell systems are the unit of biosynthesis of macromolecules and the respiratory chain. Last fact allows us to consider the biological effects of D_2^{16}O , as a complex negative effect, acting simultaneously on the functional state of the large number of systems: metabolism, biosynthetic processes, cell transport, the structure and function of deuterated macromolecules and cellular membranes. This results in inhibition of cell growth followed by cell death in D_2^{16}O . This occurs even when using the solutions of D_2^{16}O shaped with HD^{16}O . That is why it is so important to purify water from heavy isotopes of D and ^{18}O .

The systematic study of the impact of D_2^{16}O on cells of animals, plants and bacteria has started in Russia quite recently [19]. The experiments have shown that D_2^{16}O negatively affects the vital functions, slowing down the cell metabolism and inhibits mitosis in prophase; this occurs even when using the conventional natural water with increased content of D_2^{16}O or HD^{16}O [20]. In experiments on mice the laboratory animals were fed with water, 1/3 of which has been replaced by water of isotopic composition of HD^{16}O . A few days after the consumption of HD^{16}O in animals was observed dysbolism with subsequent destruction of the kidneys. With the further increasing in the concentration of deuterium in water up to 50% and more the animals died [21]. The reducing of deuterium concentration in drinking water stimulates biological processes and metabolism. This fact suggests that deuterium slows down, but protium promotes the intensification of metabolism in biological objects.

The studies have shown that heavy water is also capable of causing physiological, morphological, cytological alterations on the cell. There were marked the significant differences in the morphology of the protonated and deuterated cells of green algae *C. vulgaris*. Cells grown on D_2^{16}O -media were $\sim 2\text{--}3$ times larger in size and had thicker cell walls, than the control cells grown on a conventional protonated growth media with ordinary water, the distribution of DNA in them was non-uniform. In some cases on the surface of cell membranes may be observed the areas consisting of tightly packed pleats of a cytoplasmic membrane resembling mezosomes – intracytoplasmic bacterial membrane of vesicular structure and tubular form formed by the invasion of cytoplasmic membrane into the cytoplasm. It is assumed that mezosomes involved in the formation of cell walls, replication and segregation of DNA, nucleotides and other processes. There is also evidence that the majority number of mezosomes being absent in normal cells is formed by a chemical action of some external factors – low and high temperatures, fluctuation of pH and other factors. Furthermore, deuterated cells of *C. vulgaris* were also characterized by a drastic change in cell form and direction

of their division. The observed cell division – cytodieresis did not end by the usual divergence of the daughter cells, but led to the formation of abnormal cells, as described by other authors [22]. The observed morphological changes associated with the inhibition of growth of deuterated cells were stipulated by the cell restructuring during the process of adaptation to $D_2^{16}O$. The fact that the deuterated cells are larger in size (apparent size was of ~2–4 times larger than the size of the protonated cells), apparently is a general biological phenomenon proved by the growing a number of other adapted to $D_2^{16}O$ prokaryotic and eukaryotic cells.

The animal cells, in contrast to the cells of plants and bacteria are able to withstand up to 25–30% $D_2^{16}O$; the exceeding of this concentration results in cell death. This occurs even in solutions of HDO. The possible damage to the cellular genome by heavy isotopes in composition of water can have negative consequences for humanity. At the beginning of XXI century there was a view for the complete removal of D, ^{18}O and T from drinking water. This task is achieved by various physical-chemical methods – the isotope exchange in the presence of palladium or platinum, multistage electrolysis of water in combination with a catalytic isotopic exchange between water and hydrogen; low temperature rectification of liquid hydrogen followed by combustion of hydrogen with oxygen; the vacuum freezing of water followed by the thawing, vacuum distillation etc. For obtaining the ultrapure $H_2^{16}O$ must be used the multi-step purification of natural water by the above techniques, or synthesize water from isotopically pure gaseous elements – H_2 and $^{16}O_2$, which are pre-dried in the adsorption filter. Water of such a high degree of isotope purification is used in experiments and procedures requiring exceptional purity chemicals.

Biological effects of the DDW

Contrary to $D_2^{16}O$, water with the reduced deuterium content 60–100 ppm (deuterium depleted water, DDW) exerts a positive effect on metabolism. Experiments on animals [23] demonstrated that at the consumption of water with the decreased content of deuterium pigs, rats and mice provide a larger number of offspring, upkeep of poultry from 6 day old to puberty on the DDW leads to the accelerated development of reproductive organs (size and weight) and strengthen the process of spermatogenesis, egg laying by hens is increased by almost half, wheat ripens earlier and gives higher yields. The DDW delays the appearance of the first metastasis nodules on the spot of inoculation of cervical cancer, and exerts immunomodulatory and radioprotective effect [24].

The radioprotective effects of DDW were studied by W. Bild [25], V.S. Turusov [26] and D.V. Rakov [27] at the irradiation of mice's cells by γ -radiation at semimortal dose LD50. The survival level of animals treated with the DDW for 15 days prior to γ -radiation, was 2.5-fold higher than in control group (dose of 850 R). The surviving experimental group of mice has the number of leukocytes and erythrocytes in the blood remained within the normal range, while in the control group the number of leukocytes and erythrocytes was significantly decreased.

The consumption of the DDW by cancer patients during or after the radiation therapy treatments allows restore the composition of blood and relieve nausea [28]. According to G. Somlai, the results of clinical trials with the DDW conducted in 1998–2010 in Hungary showed that the survival rate for patients drinking the DDW in combination with traditional therapies was significantly higher than for patients who only were treated with chemotherapy or radiation therapy [29].

The biological experiments with the DDW carried out in Moscow Research Oncological Institute after P.A. Herzen and N.N. Blokhin with Institute of Biomedical Problems [30], confirmed the inhibitory effects of the DDW on the process of growth of various tumors, e.g. division of breast adenocarcinoma MCF-7 tumor cells being placed in the DDW started with a delay of ~5–10 hours. In 60 % of mice with immunosuppressed immunity and transplanted human breast tumor MDA and MCF-7 the consumption of the DDW caused tumor regression. A group of mice with transplanted human prostate tumor PC-3 consumed the DDW showed the increase in the survival rate by ~40 %; the ratio number of dividing cells in tumors of dead animals in experimental group was 1.5:3.0, and in control group – 3.6:1.0 [31]. In this regard a special attention deserves two indicators: the delay of metastasis and the loss of animal's weight during the experiments. The stimulating action of the DDW on the immune system of animals has led to delay of development of metastasis by 40% in comparison with the control group, and weight loss in animals that consumed the DDW at the end of the experiment was 2 times less. It was also reported that the DDW may delay the progression of prostate cancer [32] and inhibit the human lung carcinoma cell growth by apoptosis [33] – the programmed cell death, resulting in fragmentation of the cell into separate apoptotic bodies bounded by the plasma membrane.

The preliminary experimental results on motility of human sperm [34], indicated that in the DDW (4 ppm) spermatozoa longer retain their functional activity, and it increases with a decrease in the deuterium content of water, whereas the sperm motility is by 40% higher for 5 hours after registration. However, the effect depends on initial properties of a sperm sample. These data indicated that deuterium content variation in water including deep deuterium depletion produces various non-linear isotopic effects on key processes in the cell: enzyme action of Na, K-ATPase, regeneration, motility, fertilizing effectiveness and embryo developing. It should be noted that for any deuterium concentration dependence there should be an optimal condition for the best result.

One prominent effect of deuterium depletion is the inhibition of fatty acids as well as the synthesis, chain elongation and desaturation. These anabolic reactions utilize acetyl-CoA, as well as hydrogen of water for new fatty acid biosynthesis [35]. The fatty acids are used for new membrane formation in the rapidly proliferating cell. The complex structure and molecular organization of the mammalian fatty acid synthase (EC 2.3.1) offer remarkable opportunities with altered morphology and flux handling properties.

The positive influence of the DDW on blood chemistry included a significant reduction of glucose, cholesterol, erythrocyte sedimentation rates, leukocyte counts and cortisol (stress hormone) levels, but also revealed an increase in antioxidant capacities [36]. These data evidence the significance of the DDW to increase energy resources even in a healthy cohort, while decreasing risks of psycho-emotional stress, which is known to pose a negative influence on blood biochemistries that often lead to psychosomatic diseases and shorten life. It was also noted the positive impact of the DDW on indicators of saturation the liver tissue by oxygen: the observed increase in pO_2 was ~15 %, i.e., the cell respiration increased on 1.3 times [37]. On a beneficial effect on health of experimental mice drinking the DDW evidenced the increased resistance and weight increase compared with the control group.

The main impact of the DDW on organism evidently is explained by a gradual reduction of deuterium content in physiological fluids due to the reactions of isotopic (H–D) exchange: $D_2O + H_2O = 2HDO$. It was recorded the change in the isotopic composition of urine and Ca^{2+} content as well. Thus, the regular consumption of the DDW provides a natural way to reduce the deuterium content in the human body to a value of 110 ppm.

The clinical trials of the DDW with a residual content of deuterium 60–100 ppm, showed [38] that the DDW can be recommended as an adjunct in the treatment of patients having metabolic syndrome (hypertension, obesity, impaired glucose metabolism) and diabetes. In addition the DDW improves the quality of life for patients having renal stone disease (nephrolithiasis) and various disorders in the gastrointestinal tract (colitis and gastritis), cleanses the body of toxins, enhances the action of drugs and promotes weight correction. The DDW can be recommended for fast and deep cleaning of the human body from deuterium that is essential for metabolic disturbances. Taking into consideration the dynamics of the distribution of water in the human body, the reaction of isotopic (H/D and $^{16}O/^{18}O$) exchange and the positive results obtained with the DDW, it can be expected that the greatest effect the isotopic purification of water will have on the regulatory system and metabolism.

The total effects of the DDW depend on the total body mass, the total mass of intracellular water, the amount of daily consumption of the DDW and the degree of its isotope purification [39]. The results on the calculation of gradual increasing of deuterium content in the human body at regular consumption of the DDW with varied residual deuterium content are shown in Table 3. These results demonstrate that the content of deuterium in the human body decreases while consuming the DDW. Thus, at the consumption of water with a residual deuterium content of 60 ppm the deuterium content in the body decreases after 45 days to 117.3 ppm, and at the consumption of water with a residual content of deuterium 100 ppm – to 131 ppm at 1 liter of water consumption per a day, to 122.6 ppm at water consumption of 1.5 liters of water a day. Hence, the regular taking of the DDW provides a natural way to reduce the content of deuterium in the human body to a value of ~117 ppm.

Table 3

The gradual decreasing of deuterium content in the human body over time, with regular consumption of the DDW*

Number of days	The residual content of deuterium in water, ppm		
	60	100	100
	Daily consumption of the DDW, liters		
0	1	1	1.5
1	150,5	150,7	150,8
2	145,5	147,9	146,9
7	136,5	143,6	140,5
14	130,6	138,3	134,7
21	120,8	135,6	129,6
28	120,0	133,9	126,6
35	119,6	132,6	124,5
45	117,3	131,5	122,6

*Notes:

The calculation was performed based on the following data:

- daily consumption of the DDW – 1 or 1.5 liter;
- daily water exchange rate – 2.5 liters;
- deuterium content in the body corresponds to its content in natural water ~ 150 ppm;
- the average volume of water in the body – 45 liters (average body weight ~ 75 kg).

Installations for extraction of heavy isotopes D and T from water

Currently, there are several methods to separate the heavy isotopes of water: isotopic exchange in the presence of palladium and platinum, the electrolysis of water in combination with a catalytic isotopic exchange between water and hydrogen gas, the column fractionation, the vacuum freezing of cold vapor followed by thawing. In the preparation of deuterium-depleted drinking water due to freezing and thawing of ice, the preparation of ice is carried out by freezing of vapor produced from water at a temperature not exceeding +10 °C; in the process of thawing the ice is exposed to ultraviolet and infrared radiation, and the melted water is saturated by gas or gas mixture. When $H_2^{16}O$ and ($D_2^{16}O + T_2^{16}O$) is mixed the isotope exchange takes place:

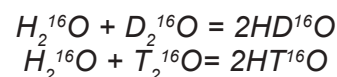

Due to the isotope exchange, deuterium and tritium are presented in ordinary water in the form of $HD^{16}O$ and $HT^{16}O$. The temperature of the freezing point for $D_2^{16}O$ makes up +3.8 °C and for $T_2^{16}O$ – +9 °C. $HD^{16}O$ and $HT^{16}O$ freeze, respectively, at +1.9 °C and +4.5 °C. It was established experimentally that at a temperature in the range from 0 to +1.9 °C the molecules of water with deuterium and tritium are in a metastable solid-inactive state as opposed to the DDW. This property is in the basis of the fractional separation of $H_2^{16}O$ and $HD^{16}O$ by means of creating the under-pressure of air above the water surface at a given temperature. The

DDW is intensively evaporates and is collected by means of a freezer unit, thus turning into ice. $D_2^{16}O$ being in the inactive solid state and having a significantly lower partial pressure, remains in the flash tank of initial water along with the salts and impurities dissolved in water. On this principle operates the engineered by G.D. Berdyshev and I.N. Varnavskiy together with R. Kavetsky Institute of Experimental Pathology, Oncology and Radiobiology (Academy of Sciences of Ukraine) the first in the world industrial installation VIN-4 "Nadya" for the production of the DDW with the reduced on 30–35% content of deuterium and tritium (Fig. 3). The installation consists of a housing 1 in which an evaporation tank 2 is set up together with the initial water heating unit 3 and cooling water unit 4. The apparatus is equipped with a valve 5 for supplying water to an evaporator 2 and a valve 6 for the draining of waste residue, enriched with heavy hydrogen isotopes.

The housing unit is positioned the device 7 for condensing and freezing the cold steam as a set of thin-walled tubular elements connected to a pump for pumping the refrigerant into the device. The device 7 together with the sources of ultraviolet 8 and infrared radiations 9 is placed over a container 10 for the collection of melt water. The internal cavity of the housing 1 is connected via a pipe 11 to a vacuum pump – a source discharge of air. Furthermore the 11 is supplanted with the device 12 for supplying to the interior cavity of the installation of purified air or mixture of gases. Additionally, the installation "VIN-4" is equipped with the temperature controlled system in the cavity of the evaporator container 2 to control the set temperature of the evaporation of initially treated water. In addition, in the housing 1 there are windows for monitoring processes of evaporation, the freezing of cold vapor and ice melting – 13 and 14. The capacity of collecting the melt water 10 is provided with a valve 15 for draining the melt water, and fitting 16 for connection to the unit forming the structure and properties of melt water 17. The control unit 17 includes an inner conical vessel 18 with minerals and dolomite. The output capacity of 19 is an adsorption filter 20 and the drain valve 21.

The alternative electrolysis installation for the production of drinking water with low content of deuterium constructed in 2000 Yu.E. Sinjak, V.B. Gaydadyomov and A.I. Grigoriev at the Institute of Biomedical Problems in Moscow [40]. The installation 1 comprises a container with atmospheric moisture condensate or distillate, which is connected to the anode electrolysis chamber 2 containing an ion electrolyte (Fig. 4). The cell comprises a porous electrode (anode 2 and the cathode 3) made of titanium coated with platinum, the converter of electrolysis gases into water, and a capacitor 10 and collector of the DDW. Furthermore, the device is provided with a desiccant of oxygen 4, the reactor 5 of isotope $D_2/H_2^{16}O$ exchange, the outer side walls of which are constructed from ion exchange membranes, and the water conditioner 11 (Fig. 4). The outer wall of the reactor 5 and the dryer 4 are constructed from ion-exchange membranes 6, 8; the oxygen dehumidifier contains cation exchanger, and the water conditioner 11 is formed from the filter with

mixed layers of ion-exchange materials – adsorbent and mineralizer containing the granular calcium magnesium carbonate materials. The condensate or distillate atmospheric moisture enters the anode chamber of the electrolytic cell with a solid electrolyte, wherein the electrolysis is carried out at a temperature of 60–80 °C. The formed in the result of electrolysis deuterium-depleted gaseous hydrogen and oxygen along with and water vapor are entered into the oxygen dryer 4, wherein the drying process takes place by sorption of water vapor by ion exchange filler (cation exchanger) and further passing through the ion exchange membrane 6.

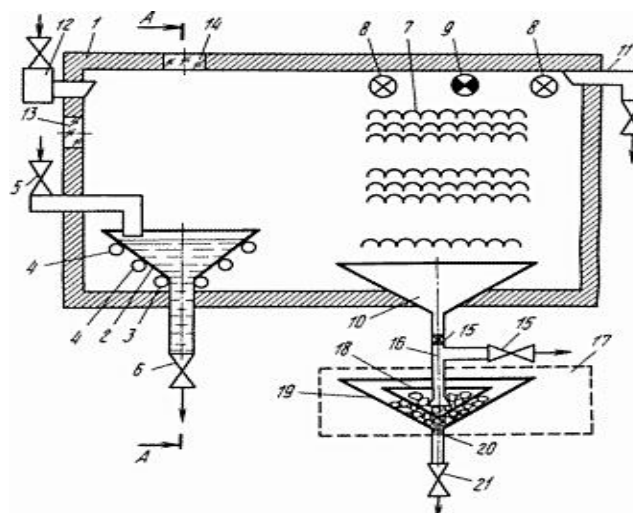

Fig. 3. – Schematic representation of the installation of VIN-4 "Nadya" (adapted from G. Berdyshev): 1 – housing; 2 – flash tank, 3 – a device for heating water, 4 – a device for cooling water, 5 – valve for the water supply to the evaporator; 6 – valve for draining spent residue; 7 – the device for condensation and freezing of the cold vapor; 8, 9 – sources of ultraviolet and infrared radiation; 10 – a tank for collecting of melt water; 11 – the vacuum pump; 12 – the device for supplying the purified air or gas mixtures; 13, 14 – portholes for observing the processes of evaporation, freezing vapor and ice melting; 15 – valve for draining of melt water; 16 – a branch pipe; 17 – the block of formation of structure and properties of melt water; 18 – internal conical container and minerals; 19 – the outer conical container with minerals; 20 – adsorption filter; 21 – the drain valve

Then, the dried hydrogen is supplied into the catalytic isotopic exchange reactor 5 where it undergoes isotopic $D_2/H_2^{16}O$ exchange with water vapor and hydrogen on a catalyst consisting of activated carbon with additives of 4–10% of fluoro-plastic and 2–4% of palladium or platinum. After the isotopic $D_2/H_2^{16}O$ hydrogen is drained from water vapor ($D_2^{16}O$) which adsorbed and removed by ion exchangers of the reactor 8, posted on its outer side walls. The drained gases enter the converter of electrolysis gases and the catalytic burner 9.

The flame torch is directed to a condenser 10, cooled in a flow by tap water wherein the water vapor is condensed and entered into the air conditioner 11 for further purification

on a sorption filter. Water then flows into the collection 12 of the DDW. The cooling of the device and the work of ion exchange membranes for drying of electrolysis gases from the water vapor is carried out by a fan 7. The final purification of water and its subsequent mineralization is carried out by calcium and magnesium containing natural carbonate minerals – dolomite or glauconite. The productivity of the device on the DDW compiles 50 ml of water per 1 hour.

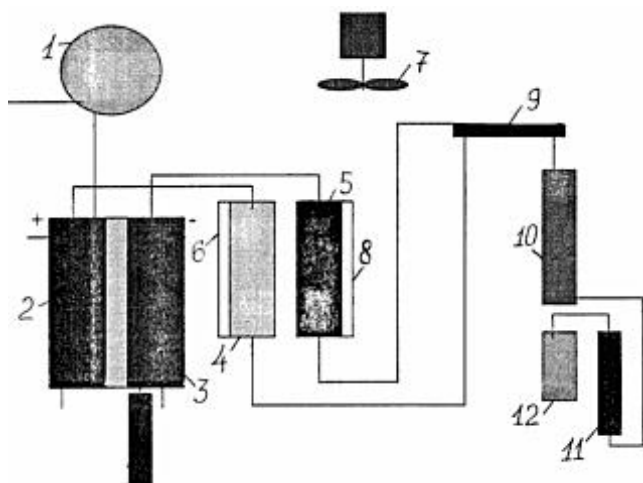
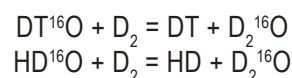

Fig. 4. – Schematic representation of an electrolysis device for producing the DDW: 1 – the atmospheric moisture condensate container; 2 – the anode; 3 – the cathode; 4 – the oxygen drier; 5 – the reactor of isotope $D_2/H_2^{16}O$ exchange; 7 – fan; 6, 8 – ion exchange membranes; 9 – the catalytic burner; 10 – the capacitor; 11 – the water conditioning unit with dolomite; 12 – a collector of the DDW

By using the vacuum freeze-thaw method it is possible to obtain the micro-mineralized drinking water with the reduced deuterium content by 30–35%. By using the electrolysis process it is possible to reduce the amount of deuterium in water by 90% or more, but water manifests the properties of distilled water (the lack of mineralization, the high content of dissolved gases, the disordered molecular structure of water). The advantage of the electrolysis process is in the maximum possible removal of deuterium (up 90%).

The developed in recent years combined methods of isotopic exchange and rectification of water allow obtain water with high isotopic purity. The world's first installation for isotope fractionation of water was designed in 1975 by Swiss Comp. "SULZER" and put into operation at the reactor of type "HFR ILL". In 1987, a similar but more powerful unit was created in Canada for Canadian nuclear power plants. In 1999 at the St. Petersburg Institute of Nuclear Physics named after B.P. Konstantinov was created the first domestic distillation column for isotopic separation of water. The height of the column compiles 10 m, the diameter – 80 mm. The basis of this installation founded on the combined method of isotope exchange in system "water vapor-hydrogen" and the low-temperature distillation of hydrogen isotopes. During the catalytic isotope exchange (CIE) between the water vapor and deuterium at +200 °C from heavy water

($D_2^{16}O$) is extracted protium and tritium, and occurs their subsequent transfer into the gaseous phase in accordance with the following chemical reactions:



The recovery of tritium from $D_2^{16}O$ is determined by the equilibrium constant and at the three-stage cleaning is not more than 30%. The purified by protium and tritium $D_2^{16}O$ is returned to the reactor. A mixture of hydrogen isotopes – D_2 , DT, HD after the purification from impurities and cooling down to 25 °K is entered into a low temperature column. Due to the mass transfer processes between gaseous and liquid phase of the hydrogen isotopes, the concentration of tritium occurs at the bottom, and protium – at the top of the column. The depleted on protium and tritium the flow of deuterium in the form of $D_2^{16}O$ returns to the CIE block. From the top of the low temperature column is carried out the concentrate of protium – in form of the DDW, and from the bottom – the concentrate of tritium in the form of tritiated ($T_2^{16}O$) water.

The rectification is carried out in countercurrent mass transfer column apparatuses with contact elements – the packing or trays. In this process there is a continuous exchange between the moving relative to each other molecules of the liquid and gaseous phases. The liquid phase is enriched with a high-boiling component and the gaseous phase – with a low boiling – D, T, and ^{18}O . In most cases, the rectification is carried out in a countercurrent column apparatuses with different contact elements. The process of mass transfer takes place over the entire height of the column between the falling down phlegm and lifting up the gas/steam. To intensify the process of mass transfer the contact elements are often used the packing and plates, thus increasing the surface mass transfer. In the case of dripping nozzles liquid water flows down in a thin film on its surface, in the case of trays the gas/steam passes through the water layer on the surface of the plates. In practice, for better extraction of heavy isotopes of D and T from water are used by more than one distillation column, but the battery of several individual columns.

The rectification method of isotope separation of water has a number of significant advantages over the electrolysis method that allows carry out the purification of natural water from deuterium to values of the order of 20–30 ppm and below. Furthermore, the productivity of isotope purification of water by this method is slightly higher that significantly reduces its cost. It is assumed that at a large-scale production of the DDW in the future it will become public.

Conclusions

According to experimental data the DDW obtained by various physical-chemical methods (the isotopic exchange in the presence of palladium and platinum, the electrolysis of water in combination with a catalytic isotope exchange between water and hydrogen, the column rectification, the vacuum freezing of cold vapor followed by thawing), has a wide range of physiological effects on the human body

(antitumor, radioprotective). The main impact of the DDW is the gradually reducing of the amount of deuterium in the physiological fluids due to the reactions of isotope (H-D) exchange. The analysis of our own and the available in the scientific literature results lead to the conclusion that the consumption of the DDW improves the functioning of vital body systems. Taking into consideration the calculated isotope effects of heavy water, and the results obtained on the DDW, it is expected that the big effect may affect the regulatory system, metabolism and energy unit of the living cell, that is, the cell systems that use the high mobility of the proton/deuteron and high the rate of rupture of chemical H- and D-bonds. The solubility of inorganic salts in the DDW is somewhat higher than in the heavy water, enabling it to more effectively excrete metabolic products and salts from the body. The rates of chemical reactions in the DDW are higher than in $D_2^{16}O$. These factors contribute to the increased use of the DDW and the development and improvement of methods to obtain it.

References

1. Mosin O., Ignatov I. Studying the biological influence of heavy water (2H_2O) on prokaryotic and eukaryotic cells // *Water: Hygiene and Ecology*. – 2015. – Vol. 3 (1). – P. 72–95.
2. Mosin O., Ignatov I. The isotopic effects of deuterium on biological objects // *Journal of Medicine, Physiology and Biophysics*. – 2015. – Vol. 10. – P. 47–71.
3. Mosin O., Ignatov I. Research of isotopic effects of deuterium in cells of microorganisms in the presence of D_2O and IR spectra in hot mineral water for origin of life // *Journal of Medicine, Physiology and Biophysics*. – 2014. – Vol. 4. – P. 45–58.
4. Lobishev V.N. Isotopic effects of D_2O in biological systems / V.N. Lobishev, L.P. Kalinichenko (eds.) – Moscow: Nauka, 2008. 215 p.
5. Ignatov I., Mosin O.V. Isotopic composition of water and its temperature in modeling primordial hydrosphere experiments / *Mat. VIII Miedzynarodowej naukowo-praktycznej konferencji "Perspektywiczne opracowania sa nauka i technikami – 2012"*. 07-15 listopada 2012. V. 15. Nauk biologicznych Weterynaria. Przemysl: Nauka i studia. – 2012. – P. 41–49.
6. Mosin O.V. Purification of water from heavy isotopes of deuterium, tritium and oxygen. C.O.K. Publishing House "Media Technology" (Moscow). – 2012. – № 9. – P. 18–23 [in Russian].
7. Ignatov I., Mosin O.V. Modeling of possible processes for origin of life and living matter in hot mineral and seawater with deuterium // *Journal of Environment and Earth Science*. – 2013. – Vol. 3. – № 14. – P. 103–118.
8. Mosin O.V. Studying the methods of biotechnological preparation of proteins, amino acids and nucleosides, labeled with stable isotopes 2H and ^{13}C with high levels of isotopic enrichment / O.V. Mosin. Autoref. disser. thesis PhD. – Moscow: M.V. Lomonosov State Academy of Fine Chemical Technology, 1996. 26 p.
9. Cleland W.N. Isotope effects on enzyme-catalyzed reactions / W.N. Cleland, M.N. O'Leary & D.D. Northrop (eds.). – Baltimore, London, Tokyo: University Park Press, 1976. 303 p.
10. Mosin O., Ignatov I. Studying the influence of heavy and deuterium depleted types of water on biological objects // *Journal of Medicine, Physiology and Biophysics*. – 2015. – Vol. 14. – P. 35–49.
11. Mosin O.V., Ignatov I. Isotope effects of deuterium in bacterial and microalgae cells at growth on heavy water (D_2O) // *Voda: Himia i Ecologija*. – 2012. – Vol. 3. – P. 83–94 [in Russian].
12. Kushner D.J., Baker A., Dunstall T.G. Pharmacological uses and perspectives of heavy water and deuterated compounds // *Can. J. Physiol. Pharmacol.* – 1999. – Vol. 77. – № 2. – P. 79–88.
13. Vertes A. Physiological effect of heavy water. Elements and isotopes: formation, transformation, distribution / A. Vertes, Ed. – Vienna: Dordrecht: Kluwer Acad. Publ., 2003. 112 p.
14. Mosin O.V., Ignatov I., Skladnev D.A., Shvets V.I. Studying of phenomenon of biological adaptation to heavy water // *European Journal of Molecular Biotechnology*. – 2014. – Vol. 6(4) – P. 180–209.
15. Ignatov I., Mosin O., Velikov B., Bauer E. Influence of isotopic composition of water with varying deuterium content in composition with mountain water of Bulgaria on human longevity // *Journal of Medicine, Physiology and Biophysics*. – 2014. – Vol. 7. – P. 46–78.
16. Lis G., Wassenaar L.I., Hendry M.J. High-precision laser spectroscopy D/H and $^{18}O/^{16}O$ Measurements of microliter natural water samples // *Anal. Chem.* – 2008. – Vol. 80. – № 1. – P. 287–293.
17. Ignatov I., Mosin O.V., Bauer E. Mathematical model of melt water and mountain water from Bulgaria obtained by IR, NES and DNES-methods // *Journal of Medicine, Physiology and Biophysics*. – 2015. – Vol. 17. – P. 30–52.
18. Ignatov I., Mosin O.V. // Modeling of possible conditions for origin of first organic forms in hot mineral water // *European Journal of Molecular Biotechnology*. – 2014. – Vol. 6. – № 4. – P. 169–179.
19. Mosin O.V., Skladnev D.A., Shvets V.I. Studying physiological adaptation of microorganisms to heavy water // *Biotechnology*. – 1999. – Vol. 8. – P. 16–23.
20. Mosin O.V., Ignatov I. Biological influence of deuterium on prokaryotic and eukaryotic cells // *European Journal of Molecular Biotechnology*. – 2014. – Vol. 3. – № 1. – P. 11–24.
21. Badin V.I., Gasteva G.N., Drobyshevskiy Y.V. Study the behavior of water with negative deuterium isotope shift in the body of calves // *Proceedings of the Academy of Industrial Ecology*. – 2004. – Vol. 3. – P. 73–78 [in Russian].
22. Eryomin V.A., Chekulayeva L.N., Kharatyan F.F. Growth of *Micrococcus lysodeikticus* on a deuterated medium // *Microbiologia*. – 1978. Vol. 14. – P. 629–636 [in Russian].
23. Andreeva E.I., Konstantinova N.A., Burovkova L.B., Sinyak E.I. Effect of different isotopic composition of water on the proliferative activity of endothelial cells in vitro // *Aerospace and Environmental Medicine*. – 2005. – Vol. 39. – № 3. – P. 46–52.
24. Rakov D.V. Effects of water with a low content of deuterium and oxygen ^{18}O on the development of radiation injury after gamma irradiation // *Aerospace and Environmental Medicine J.* – 2007. – Vol. 41. – P. 36–39.
25. Bild W., Stefanescu I., Haulica I. Research concerning the radioprotective and immunostimulating effects of deuterium-depleted water // *Rom. J. Physiol.* – 1999. – Vol. 36 – № (3–4) – P. 205–218.
26. Turusov V.S., Sinyak Y.E., Antoshina E.E. Study of radioprotective action of water with a low content of deuterium with a single exposure to high doses of radiation. *Rus. Biotherapeutic Journal*. – 2005 – Vol. 4. – № 1. – P. 92–98.
27. Rakov D.V., Erofeev L.M., Grigorenko D.E. Influence of water with low content of heavy stable hydrogen isotope deuterium and oxygen (^{18}O) on the development of radiation damage in gamma-irradiated at low dose. *Radiation Biology. Radioecology*. – 2006 – Vol. 46 – № 4 – P. 475–479.

28. Olariu L., Petcu M., Cuna S. The role of deuterium depleted water (ddw) administration in blood deuterium concentration in Cr(VI) intoxicated rats // *Lucrari stiintifice medicină veterinară (Timișoara)* – 2010 – XLIII (2) – P. 193–196.

29. Somlyai G. The biological effect of deuterium-depleted water. A possible new tool in cancer therapy. *Anticancer Research Intern. J.* – 2001 – Vol. 21. – № 3. – P. 23–33.

30. Grigoriev A.I., Zaridze D.G., Turusov V.S. The effect of water with a low content of deuterium on transplantable tumors // *Problems of Oncology.* – 2005 – Vol. 1. – P. 99–102 [in Russian].

31. Turusov V.S., Antoshina E.E., Trukhanova L.S., Gorkova T.G., Sinyak E.Y. Growth of transplanted tumors in mice after injecting into them water with decreased deuterium content // *Problems of Oncology.* – 2006 – Vol. 1 – P. 59–62 [in Russian].

32. Kovács A., Guller I., Krempels K. Deuterium depletion may delay the progression of prostate cancer // *Journal of Cancer Therapy.* – 2011 – Vol. 2 – P. 548–556.

33. Cong F., Zhang Y., Sheng H. Deuterium-depleted water inhibits human lung carcinoma cell growth by apoptosis // *Experimental and therapeutic medicine.* – 2010 – Vol. 1 – P. 277–283.

34. Lobyshev V.I., Kirkina A.A. Biological effects of deuterium content variation in water / in: 2nd International Congress on Deuterium Depletion. – Budapest, Hungary, 17–18 May, 2012.

35. Boros L.G., Somlyai G. Tracer substrate-based metabolic profiling, phenotypic phase plane and regression matrix analyses of pancreatic cancer cells under deuterium depleted growth environment / in: 2nd International Congress on Deuterium Depletion. – Budapest, Hungary, 17–18 May, 2012.

36. Burdeynaya T.N., Chernopyatko A.S. Physiological effects of drinking water enriched with ¹H and ¹⁶O / in: 2nd International Congress on Deuterium Depletion. – Budapest, Hungary, 17–18 May, 2012.

37. Kolesov O.E., Pomytkin I.A. Influence of natural concentration of heavy water isotopologues on the rate of ²H₂O generation by mitochondria // *Bulletin of Experimental Biology and Medicine.* – 2006 – Vol. 11 – P. 514–516.

38. Turova E.A., Holovatch A.V., Timakov A.A., Akimov B.K. Influence of water with reduced isotopes of hydrogen and oxygen on the patients with metabolic syndrome / in: interdisciplinary conference with international participation “New Biocybernetic and telemedicine technologies of XXI century”. – Petrozavodsk, 23–25 June 2003, 28 p.

39. Ignatov I., Mosin O.V., Velikov B., Bauer E., Tyminski G. The mountain water as main longevity factor in multifactorial research of phenomenon of longevity in mountain areas of Bulgaria // *Water: Hygiene and Ecology.* – 2015 – Vol. 3. – № 1–2 – P. 25–53.

40. Sinyak Y.E., Grigoriev A.I., Gaydadyanov V.V. The method of obtaining water and bezdeyterioy study its effect on the physiological status of the Japanese quail. *Space Biology and Aerospace Medicine* / in: *Proceedings of XI Conference.* – Moscow, 1998 – Vol. 2 – 201 p.

UDC 543.42.062: 577.3

ISOTOPE PURIFICATION OF DRINKING WATER FROM HEAVY ISOTOPES – DEUTERIUM (²H), TRITIUM (³H) AND OXYGEN (¹⁸O)

*O. Mosin, **I. Ignatov

*Moscow State University of Applied Biotechnology, Russian Federation;

**The Scientific Research Center of Medical Biophysics (SRCMB), Bulgaria

This paper deals with the theoretical, scientific and practical issues of isotopic purification of drinking water from heavy isotopes – D, T, and ¹⁸O. The authors conducted the research into the deuterium isotope effects in different cells of various biological objects of microbial, plant and animal origin as a result the conclusion was made about the complex multivariate deuterium impact on the organism and the need for consumption the drinking water with a reduced content of deuterium. The effects of deuterium on organism possess a complex multi-factorial character and connected to cytological, morphological and physiological changes. The maximum kinetic isotopic effect observed at ordinary temperatures in chemical reactions leading to rupture of bonds involving hydrogen and deuterium atoms lies in the range $k_H/k_D = 5-8$ for C–H versus C–D, N–H versus N–D, and O–H versus O–D-bonds. The deuterium depleted water (DDW) with the decreased deuterium content (60–100 ppm) has beneficial effects on organism and the removing of deuterium. The design of devices is given that allow purify water from deuterium with the decreased on 30–90% content of deuterium (depending on the method).

Key words: deuterium, tritium, oxygen-18, heavy water, deuterium depleted water, isotopic purification.

УДК 543.42.062: 577.3

ИЗОТОПНАЯ ОЧИСТКА ПИТЬЕВОЙ ВОДЫ ОТ ТЯЖЕЛЫХ ИЗОТОПОВ – ДЕЙТЕРИЯ (²H), ТРИТИЯ (³H) И КИСЛОРОДА (¹⁸O)

*О.В. Мосин, **И. Игнатов

*Московский государственный университет прикладной биотехнологии, Российская Федерация; **Научно-исследовательский центр медицинской биофизики (НИЦМБ), Болгария

В статье рассматриваются теоретические и научно-практические вопросы изотопной очистки питьевой воды от тяжелых изотопов – D, T, и ¹⁸O. Авторы провели исследование изотопных эффектов дейтерия в клетках различных биологических объектов микробного, растительного и животного происхождения, в результате был сделан вывод о сложном негативном многофакторном воздействии дейтерия на организм и необходимости потребления питьевой воды с пониженным содержанием

дейтерия. Эффекты дейтерия на организм обладают сложным многофакторным характером и связаны с цитологическими, морфологическими и физиологическими изменениями. Максимальный кинетический изотопный эффект, наблюдающийся при обычных температурах в химических реакциях, приводящих к разрыву связей с участием атомов водорода и дейтерия, находится в диапазоне $k_H/k_D = 5-8$ для C-D, N-D и O-D-связями. Бездейтериевая вода (БДВ) с пониженным содержанием дейтерия (60–100 ppm на миллион) оказывает положительное влияние на организм и выведение дейтерия. Приведена конструкция установок, позволяющих очищать воду от дейтерия на 30–90% (в зависимости от метода).

Ключевые слова: дейтерий, тритий, кислород-18, тяжелая вода, бездейтериевая вода, изотопная очистка.
УДК 543.42.062: 577.3

ИЗОТОПНЕ ОЧИЩЕННЯ ПИТНОЇ ВОДИ ВІД ВАЖКИХ ІЗОТОПІВ – ДЕЙТЕРІЮ (^2H), ТРИТІЮ (^3H) ТА КИСНЮ (^{18}O)

***О. В. Мосін, **І. Ігнатів**

**Московський державний університет прикладної біотехнології, Російська Федерація;
**Науково-дослідний центр медичної біофізики (НІЦМБ), Болгарія*

У статті розглядаються теоретичні та науково-практичні питання ізотопного очищення питної води від важких

ізоотопів – D, T та ^{18}O . Автори провели дослідження ізоотопних ефектів дейтерію в клітинах різних біологічних об'єктів мікробного, рослинного і тваринного походження, в результаті був зроблений висновок про складний негативний багатофакторний вплив дейтерію на організм і необхідність споживання питної води із зниженим вмістом дейтерію. Ефекти дейтерію на організм володіють складним багатофакторним характером і пов'язані з цитологічними, морфологічними і фізіологічними змінами. Максимальний кінетичний ізоотопний ефект спостерігається при звичайних температурах в хімічних реакціях, що призводять до розриву зв'язків з участю атомів водню і дейтерію, знаходиться в діапазоні $k_H/k_D = 5-8$ для C-D, N-D і O-D-зв'язками. Бездейтерієва вода (БДВ) із зниженим вмістом дейтерію (60–100 ppm на мільйон) позитивно впливає на організм і виведення дейтерію. Наведено конструкцію установок, що дозволяють очищати воду від дейтерію на 30–90% (залежно від методу).

Ключові слова: дейтерій, тритій, кисень-18, важка вода, бездейтерієва вода, ізотопна очистка.

Впервые поступила в редакцию 22.08.2015 г. Рекомендована к печати на заседании редакционной коллегии после рецензирования.

УДК: 61: 613.-613.2. – 613.62- 615.245 - 615.246

ВПЛИВ ПРОСТОГО ОЛІГОЕФІРУ МАРКИ ЛП-2102 ТА 2-МЕТОКСИЕТАНОЛУ НА ВМІСТ АДАПТИВНИХ ГОРМОНІВ І ЦИКЛІЧНИХ НУКЛЕОТИДІВ У ЩУРІВ

В.П. Кучеренко, М.Г. Щербань, В.О. Телсгін, Л.І. Артюгіна
Харківський національний медичний університет, Україна

Вступ

Проблема санітарної охорони водойм від забруднення промисловими стічними водами на даний час є особливо гострою у зв'язку з інтенсивним розвитком хімічної промисловості та хімізацією всіх галузей народного господарства [2, 7]. Упровадження нових методів синтезу та широке застосування тісно пов'язані з надходженням хімічних речовин до водойм, що призводить до обмеження їх використання для господарсько-побутових і культурно-оздоровчих цілей [5, 6]. Це, у свою чергу, може призвести до погіршення санітарних умов життя населення та забезпечення його доброякісною питною водою, а також до негативного впливу на здоров'я. Прості олігоєфіри (ПОЕ), зокрема новий представник технічної назви «Лапроли» марки 2102 (ПОЕ-Лп-2102), характеризуються значними об'ємами синтезу та широким використанням у різних галузях народного господарства, що обумовлює їх надходження до водних джерел і можливість негатив-

ного впливу на здоров'я населення [4]. З іншого боку доведено, що ПОЕ піддаються гідролітичній деструкції та трансформації з утворенням небезпечних для організму продуктів, серед яких є вивчені у токсиколого-гігієнічному відношенні (наприклад, спирти, вуглеводні, альдегіди), а також ті, що потребують такої оцінки (наприклад, 2-метоксиетанол) [1]. У зв'язку з цим виникає необхідність наукового обґрунтування потенційної небезпеки ПОЕ-Лп-2102 і 2-метоксиетанолу (2-МЕ) шляхом вивчення провідних ланок механізмів їх біологічної дії.

Виявлена раніше проведеними дослідженнями [3] інтенсифікація процесів перекисного окислення ліпідів у щурів при тривалій дії ПОЕ та продуктів їх деструкції можна розглядати як загальну метаболічну ланку оксидативного стресу. Останній, як правило, є причиною активації відповідних стрес-реакцій організму, наприклад, через гіпофізарно-кортикоадреналову та симпатoadреналову системи, які практично не вивчені за умов тривалої